



THE LONG ISLAND SCALE MODEL SOCIETY

NEWSLETTER

VOLUME 15 NUMBER 6

June 2008

Executive Board

President:	Robert DeMaio	(631)981-8201	taurleo@optonline.net
Vice President:	Henning Seidel		hseidel@optonline.net
Corresp'ndng Secty:	John Musolino	(516)713-6388	lisms@juno.com
Recording Secty:	(empty seat)		
Treasurer:	Bernie Vogelman	(516)826-6570	grandsevens@verizon.com
Editor:	Steve Muth	(561)671-9456	sgmuth@optonline.net
Contest Chairman	Fred Seitz	(631)581-1990	seitzfjs3@gmail.com
Contest Co-Chairman	Richie Marotta	(631)207-1979	richardmarotta@optonline.net
Website	John Musolino	(516)713-6388	lisms@juno.com

The **Newsletter** is published monthly by the LISMS.
Mailing Address is 70 The Promenade, Glen Head, NY 11545
The Long Island Scale Model Society is an IPMS chartered organization.
LISMS Web site: [HTTP://longislandscalemodel.tripod.com](http://longislandscalemodel.tripod.com)

The Prez Sez - Bob DeMaio

Many thanks to Matt for that DVD he turned out on RepLIcon and Mosquitocon pictures! It certainly was impressive. What will you do for next year? Matt told me that the coffee will return this month. I don't know why it was so hot at the last meeting but I asked Henning to check it out with the Community Center for air-conditioning in the summer. We didn't seem to have any problem staying warm this winter. This month is time again to finish what you're building and enter the quarterly contest! The Theme Award for this contest is a category for ANY MODEL NOT PLACED IN OUR PAST CONTESTS!!!! Bring them back guys! Looking ahead into July, we would like Seamus to give us his further details on what he uses for building materials.

Matt sent in what our club is doing to support our troops into IPMS and we are posted on the website. If you go to <http://www.ipmsusa.org/> and click What's New, you can see the LISMS posting. Thank you again, Matt!

I'm updating the Midway display list for the CAM display. It appears that we are looking at Saturday, September 13, or 20. I will be checking with Tom at the CAM for us to do the Make-n-Take for them on Saturday October 4th. We could use someone, or two of you out there to build the 1/700 scale American carriers. I'll have the lists with me at the club meeting for everyone to see, and maybe build something??

For those of you who do not know, New Jersey announced they're hosting the Region II Convention in October 2009! Hints seem to be in the Camden area.

We seem to have several members who will soon be ex-members. Dues were due in March

and this is June. We will be removing you off the e-mailing/ mailing list after this meeting. The cost is minimal and just about less than any model kit on the shelf. Stay a member and enjoy our meetings. We always ask for your input in the club. It's up to up to verbalize your feelings. Please see Bernie at the meeting to reinstate your membership and stay with us.

That's about it for now. I hope to see all of you at the meeting!

Build that model....

Bob

Old Kit Review: MPC 1/72 Profile Series

Sal Picataggio

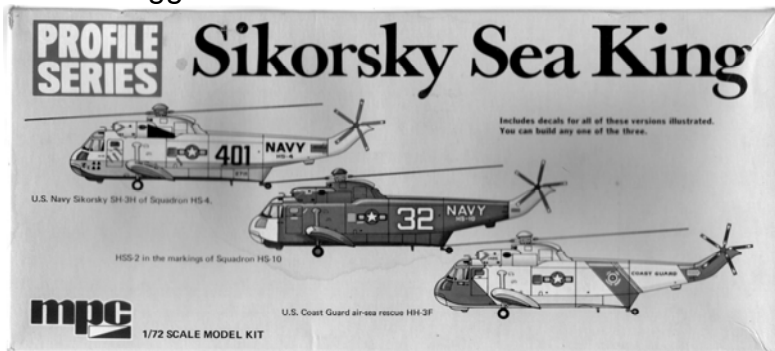

Profile Publications appeared in the early 1960s. Published in England, they were a series of booklets dedicated to a specific aircraft or variant of that aircraft. Each included text which recounted the history of the airplane along with photos to illustrate. The best part of each was the full color multi-view drawing of one particular aircraft of that type, along with a number of full

color profiles to show the aircraft in other markings. For the modeler with an historical interest, this was a godsend as now he could build models of actual aircraft with the research already done for him! And he had a full range of options to choose from!

About ten years later, MPC (Model Products Corp. of Michigan) brought out its Profile Series of 1/72 scale models. Each kit offered the builder a choice of three markings options to choose from based on the Profile Series of booklets. You could even order the Profile booklet itself using the form on the instruction sheet. MPC was the US distributor of Airfix models at the time, so the subjects included the F4F Wildcat, Spitfire, Hurricane, P-51, P-39, P-47, SBD Dauntless, Ju-88, Ju-52, PB4Y, and F-111 to name a few. According to John Burns' Collectors Value Guide for Plastic Model Kits, over thirty 1/72 Airfix kits appeared in this range. To this (at the time) 14 year old airplane/history buff, this was manna from heaven!

So much for the good news. Now, the bad news. The MPC/Airfix models were of distinct variants of each airplane, but NOT necessarily the variant of the Profile! Thus, while the F4F Wildcat decals were for the F4F-3 early version of the Wildcat, the plastic in the box was an FM-2, which was the last version of the Wildcat built. So many differences existed between the F4F-3 and FM-2, you technically couldn't use the decals without performing a major conversion! The Hurricane was the same- the decals were for the Mk I, while the kit was a Mk IV. The Mk IV had a slightly longer nose and more "pointy" spinner. It had no gun armament, but did carry rocket projectiles- which could not be used with the kit decals. The He-111 decals were for the version which had a sliding greenhouse dorsal gun position, while the kit was the late model airplane with a power turret. The Airfix P-39 was a "Q" variant with under wing gun pods. The Profile aircraft were earlier versions which didn't have these. Additionally, these WERE Airfix kits, and some were not the best in terms of accuracy, like the P-51D Mustang (Airfix's first attempt at the P-51; they would later do an excellent P-51B and D/K) or the B-25 Mitchell. To be fair, MPC got some of the kits right- the B-24J, the P-61 Black Widow, and the OS2U Kingfisher come to mind.

Finally, the REALLY bad news. MPCs decals were never the best, some being printed

as one thick sheet. The modeler had to cut each marking apart to use them. Here, unfortunately, they also were of a lighter, washed-out color in some cases. Some decals used the printing process which put small, visible dots of color on the sheet. Some sheets were usable, some not.

While the idea behind the series was excellent, the execution left something to be desired. One good thing to come out of this was that it taught this modeler to do his own research- always try to independently verify the model AND the decal options. It would be left to Revell to bring out its own series- the Collector's Choice Series a few years later- to get it right. However, that's another story for another day. Always be wary, and happy modeling!

Calendar

June 24th, 2008, LISMS Meeting, Quarterly club contest. Theme award - Any model that has not placed in a previous contest.

June 28, 29, 2008, Ft. Drum Centennial Celebration, Ft. Drum, NY, Call (315)772-4480.

July 4th, 2008, American Airpower Museum Air Show? Farmingdale, Republic Airport.

July 22nd, 2008, LISMS Meeting, TBA

August 6th – 9th, 2008, IPMS Nationals, VA Beach, VA, Looking to split the cost of a ride?

Contact Howie Belkin at hab69@aol.com or 631-849-2118.

August 26th, 2008, LISMS Meeting, TBA.

September 23rd, 2008, LISMS Meeting, Quarterly club contest.

October 28th, 2008, LISMS Meeting, TBA.

November 25th, 2008, LISMS Meeting, Last quarterly club contest of the year.

Kit Review

Pegasus 1/48 V-2 Rocket, #8416, \$10.00 Steve Muth

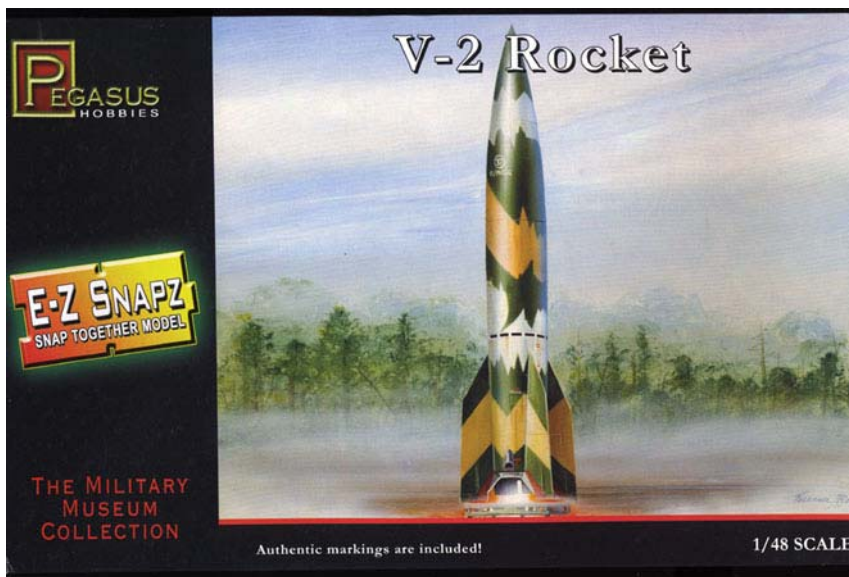

You remember Pegasus, the manufacturer that produced kits under license of some rather obscure private aircraft (like the Ercoupe). Well, they may have just hit a niche that really needs filling. 1/48 snap together models that are easy to build for youngsters over 14 years old (and oldsters). They have just introduced about six kits of popular subjects – Me 262, Me 109, Spitfire, Hurricane, Yak, and V-2. (no American Aircraft!) They sell for about \$10.00 ea., within financial reach of kids.

These are what we should be using for MnT!

I bought the V-2 Rocket just to see what they are about. Well, for your \$10 you get a V-2 and its launch table. There are 14 olive injection molded parts that press together. The fin

attachment is very clever and positive and results in a clean joint. There are even exhaust vanes. The surface detail and panel/rivets are recessed but a little on the heavy side. Surface texture is rough but won't be apparent under a coat of dull paint. There is a small decal sheet appropriate to production missiles, a painting diagram for the splinter camouflaged birds and a sheet of colorful stick ons for the artistically inclined small fry – shark mouth, skull, etc.

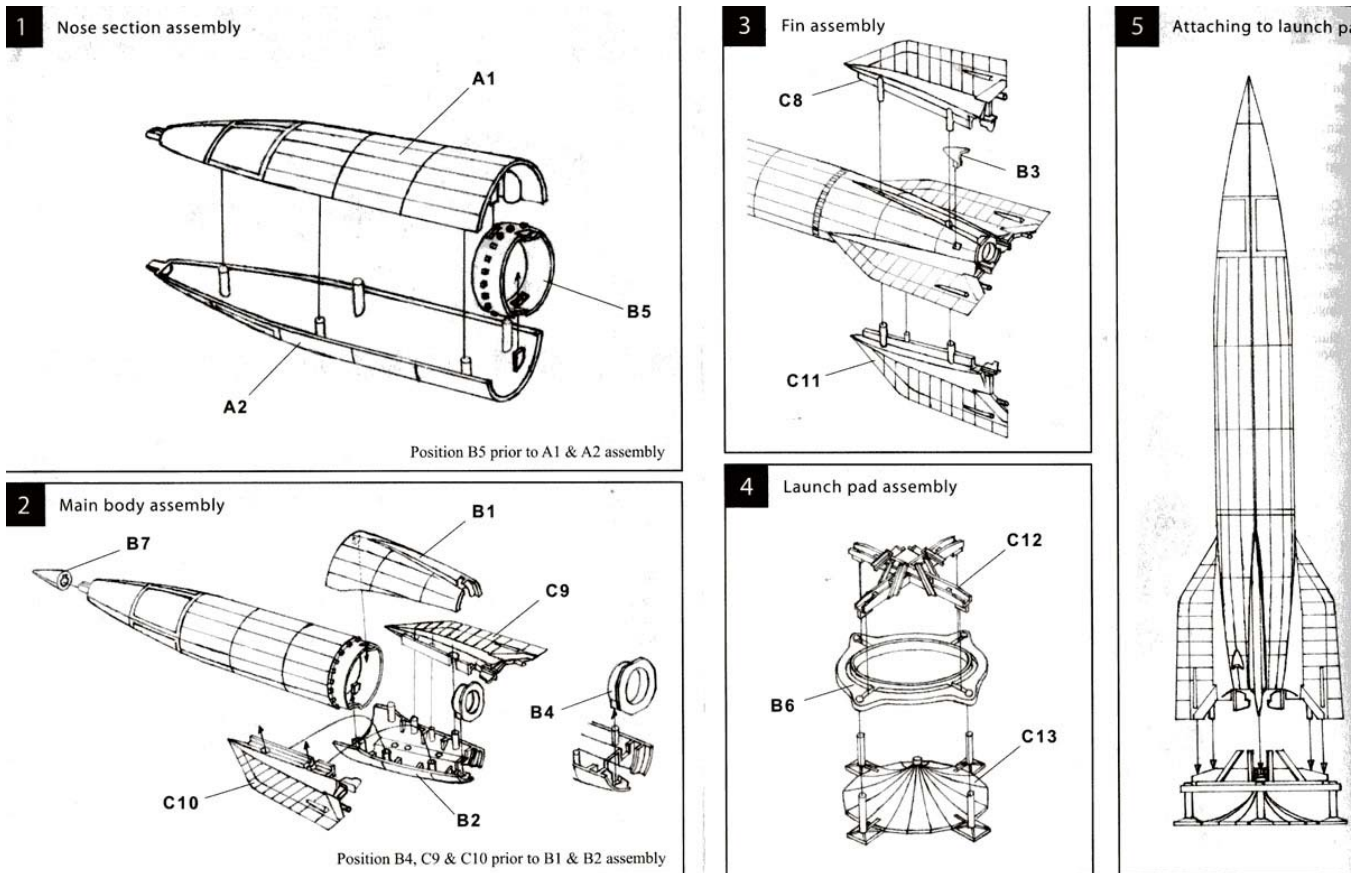

All you need to assemble one of these jems is a small nail file and 220 sand paper to clean up the small amount of flash and gate stubs, but even that is not really necessary to get the thing together. The gates are located in unobtrusive places where ever possible and the ejection pin marks were in places that didn't matter. Someone put a lot of thought into the mold making. There were four small sink on the rocket body and there were very shallow. It probably won't even be visible when painted.

Building the Model

In assembling the kit there are two things worth pointing out. 1. It is not a snap together but rather a press together, making mistakes difficult to correct. 2. You really should follow the correct assembly sequence (follow the directions) particularly in assembling the aft body section. It is not perfectly clear but the B2 aft body section must be caught on the tab in the aft forward body assembly then the aft body plug, B10, placed on it. With that done the the two fins are placed on the pegs and the B1 aft body section placed on top being sure it catches on the tab like the B1 part did. The assembly is then squeezed closed.

It does take a fair amount of squeezing to join the body halves together so this kit is not for kids without some strength in their hands. It also takes a little dexterity to hold all the aft

body parts in place when pressing them together. Once squeezed together it will take an adult or strong teenager to get them apart again.

The launch pad was cleaned up a little but could have been assembled as is. There was little real flash so I just broke some of the sharper edges and cleaned up the gate points. There are only three parts.

For painting I just used rattle cans; Tamiya paints – TS-7 Racing white, TS-28 Olive Drab 2, and TS-46 Light Sand for the Rocket and Panzer Yellow for the launch pad. After the paint had thoroughly dried the rocket body was smoothed down with very fine steel wool to take the edge off the color edges and the decals were applied. After two days to let them dry the whole thing was given a coat of Dullcote.

There are two errors in the painting instructions. The first is the color of the exhaust vanes. They call out silver but the exhaust vanes are carbon blocks not steel and so should be dull black. The second is calling out gunmetal for the launcher. I doubt this. I believe it should be either Panzer Yellow or Gray. Of course, I think it would rapidly be discolored from the flames of a launch to a burnt metal. So maybe gunmetal isn't far off. The missile itself would not be weathered since most were fired within days of manufacture.

All in all I really enjoyed building this kit. It goes quickly and is rewarding. And... it looks right when completed. This is truly a weekend build with most of the time waiting for the paint to dry between colors. A kid, using acrylics with a brush could build the whole thing in several hours and have something he can show off to his friends and family. No glue either! I hope this concept takes off. 1/72nd snap together kits were too small with delicate parts. They could be discouraging to "newbies". 1/48 is the right scale. If I build another one I will use glue and a little seam sealer on the rocket body but that in no way detracts from an excellent kit for what it is.

Mini Book Review

German Aircraft in The Soviet Union and Russia, Y. Gordon & S. Komissarov, Midland Publishing, 2008, \$43, 319 pages, HC –

Many new photos and three views. An excellent description of the Russian purchases and capture of German aircraft up to and including World War 2, including their evaluation and analysis. There is a whole chapter on their testing of the German jets. Also described is their continuing development of some German aircraft such as the Swept forward wing Ju 287 and V-1.

Written from Russian sources this is an excellent book and a bargain to boot.

Highly recommended.

Steve Muth



From Jim Boulukos we get a timely news item. The Future of MODELx Magazine

Over the past few months it became clear to the MODELx team that the editorial vision held by the editor and that held by the other staff members was not meshing in the way we had hoped when we launched the project. Following discussions, it was decided that the editor and MODELx would go their separate ways. We wish him the best in his future endeavors.

Being a small creative team to begin with, this loss is significant from a production standpoint. Mike Rinaldi, our visual coordinator, is, as we're sure our readers will agree, a very talented modeler and designer, but even with him taking a larger role in the production of the magazine it will be impossible to maintain a bi-monthly production schedule.

Because of these realities, we've decided to temporarily suspend our bi-monthly publication schedule effective with issue #2. But let us stress that MODELx is NOT DEAD. We believe that the overall concept of MODELx, as we have established it, is a sound one and we remain devoted to the idea of seeing this expressed in the print medium. Mike Rinaldi and the rest of the MODELx team will continue to work on material for future publications.

At this point, one of our favorite ideas is that of an annual publication. We envision a large format, 200+ page book showcasing fantastic scale modeling from all regions of the hobby and the world. To truly apply the methods that we have developed, we think this format and frequency are the best. The actual publication interval would probably be more like eight months and the book may even be hard cover. A good comparison might be some of the niche modeling titles that have appeared over the last several years from Japan and Scandinavia.

Of course, while we're mulling our options, it would hardly be fair to ask our subscribers, who paid on the presumption that they'd be getting bi-monthly copies, to wait for an undetermined amount of time for their next issue. So we'll gladly honor requests for refunds of unused portions of subscriptions.

If you wish, you may also retain a credit against a future publication bearing the MODELx name. Alternatively, you may also transfer your credit to Ampersand Publishing towards purchase of any of their fine publications. We will need to ask for your patience while we process your requests.

Should you want a refund, we will pro-rate the subscriptions at \$7.50 per issue, so those who have received two magazines will be refunded \$30.00 and those who have received one will be refunded \$37.50. Of course, those who have not received anything will be refunded the full \$45.00. The Pilot Issue is NOT included in any of these transactions. It was and remains complimentary. It's still available as a free download from the menus at left.

We'll keep the website updated with details of our plans for future publications. Again, we remain committed to the project, and are very encouraged by all the positive feedback we've received both directly from our readers, and seen on the Internet.

With our thanks, The MODELx Team

This post was off the Model x magazine's web site. It appears that Jeff Herne and the others had some differences and he is gone. It looks like the magazine will be an annual down the road. Boy, we all hate to lose any model related publications. MODELx has ended regular publication as a magazine and is instead switching to a larger, less frequent format. As such, they are no longer accepting subscription orders. Anyone who signed up for a subscription can get a refund. Some of us still remember Military Modeling Preview (MMP) who did all the kit reviews without painting any of the built up models. It was a great magazine that lasted for a few years back in the early 1990's. He called it the way it was and was very honest with the kit assessments

Jim Boulukos

SUPPORT YOUR LOCAL HOBBY SHOP

The following Hobby Shops have supported us and are supporting us by paying for ad space here and on our web. Some have also donated raffle prizes for our meetings and our annual RepLIcon. **We owe it to them to patronize their store** even if we could buy the item for a slightly lower price mail order or on the web. And don't forget to mention that you are a member of the LISMS and appreciate his or her support. Everybody likes a thank you.

Visit the supporting Hobby Shop nearest you if you want to have a Hobby Shop near you.

Alsand's Toy Soldiers Plus, Alan & Sandy, 84 Long Island Ave., **Dear Park**, NY 11729, (631)254-2650, www.alsandmdseco.com – Collectible, Action Figures, Miniature Toy Soldiers, Models, etc.

Baseline Model Inc., 250 Little East Neck Rd., **West Babylon**, NY 11704, (631)376-0060, Military Model Specialist, old and new kits bought and sold. Retail and Mail Orders. Closed Mondays.

Get It On Paper, Gary Weickert, 185 Maple St., **Islip**, NY 11751, (631)581-3897, open every Saturday noon to 5 PM. – Vintage Toys & Model Kits, Automobilia & auto Literature. Model kits wanted.

Gold Coast Hobby, Charles Gonder, 8 railroad Ave, **Glen Head**, NY 11545, (516)759-9094, www.GoldCoastHobby.com – Planes, Boats, Cars & Armor. A full line hobby shop dedicated to customer service.

Men-At-Arms Hobbies, James Katana, 134 Middle Country Rd.(Rt. 25), **Middle Island**, NY (631)924-0583– Excellent selection of lead miniatures-Historical and Fantasy. Plastic Models, Wargames & Modeling supplies. Books and Magazines.

Hurricane Hobbies, 2425 Middle Country Rd., **Centereach**, NY 11720, (631)737-3157 – For All Your Hobby Needs.

The Marx-Man, John Stengel, 72-50 66th St., **Glendale**, NY 11385, (718)418-9439 – We carry an array of toy soldiers in plastic and metal, from HO to 54 mm/60 mm. Die cast vehicles and Dragon action figures.



The Long Island Scale Model Society
C/O Steve Muth
70 The Promenade
Glen Head, NY 11545

TO:

Our June meeting will be Tues June 24th at 8:00PM at the Yours Ours Mine Community Ctr, 152 Center Ln, Levittown, NY 11756.

Coming East from Wantagh Parkway on Hempstead Tpke it's the next right after Shelter La (the street the library's on), or coming from the East it's the left before the left for Shelter La. It is about 1/2 mile south of Hempstead Tpke.

Don't forget this month is the second **Quarterly Contest. Special Theme award for models that did not place in previous contests. Bring something just so the rest of the models don't get too lonely and do something rash.**